

SULPHUR FROM SMELTER GASES AND SULPHATE-RICH EFFLUENTS

Jannie Maree
Environmentek CSIR

Dieks Theron
Key Structure Holdings

Ryneth Nengovhela
Environmentek CSIR

Patrick Hlabela
Environmentek CSIR

ABSTRACT

In extracting base metals from ore bodies, sulphide as well as oxide, the main environmental concern is sulphur, whether in the form of sulphurous gases or sulphate in liquid form. Generally sulphur is in over supply in developed countries mainly because of strict legislation to capture it. In developing countries on the other hand there is usually a shortage of sulphur because of less strict environmental legislation. Africa falls in this second category and the African continent imports substantial amounts of sulphur despite the fact that large quantities of sulphur is emitted by smelters, thermal power stations, coal mines, fertilizer manufacturers and others. Other than making acid from gaseous emissions, existing methods to capture sulphur from gaseous and liquid effluents are uneconomical and it ends up in the environment either as ammonium sulphate (from gaseous effluents) or as gypsum (from liquid effluents).

The CSIR's Environmentek and Pyroserv has developed a process whereby gaseous sulphur emissions and sulphates in liquid effluents can be economically captured and converted into elemental sulphur and metal carbonates. The elemental sulphur is of high purity as it is precipitated from a gas stream and is readily marketable. The metal carbonates (barium or calcium) can be recycled back to the process or marketed. The only

harmful byproduct of the process is carbon dioxide. Should natural gas or methane be available the carbon dioxide could be reduced by about one third. Should solar, wind or hydro energy be available to generate hydrogen the carbon dioxide emissions would be zero.

Employing this technology could make Africa independent of sulphur imports and furthermore reduce the impact of acid rain and seepage of sulfate from gypsum and other waste dumps into the environment.

1 INTRODUCTION

Environmental concerns often dictate whether a new ore body will be exploited or whether an existing operation will be allowed to continue. It is therefore no surprise that over the past decade a number of base metal smelters have closed ¹ and very few new ones are being planned. Indeed research is increasingly aimed at hydrometallurgical methods of metal extraction, even from sulphide ore bodies. In smelters the main environmental problem is gaseous sulphur emissions whereas hydrometallurgical operations are constrained by liquid effluents. In both cases, apart from green house gases, the main culprit is sulphur, whether present as sulphur dioxide or as sulphate.

2 SULPHUR CAPTURE FROM SMELTER GASES

In first world countries base metal smelters make sulphuric acid from their smelter gases, even though they may not have a direct need for acid. There are some exceptions such as Boliden's Skelleftehamn smelter who, apart from acid also makes liquid SO₂ as they have a ready market in Sweden's nearby paper and pulp industry. As far as we know no smelter currently makes elemental sulphur from their gaseous effluents, since the Norilsk (Russia) and BCL (Botswana) sulphur plants closed down some years ago.

In Africa and other third world countries the norm is to make acid if you have a use for it and if the gas stream is concentrated enough to allow it. Otherwise gases are scrubbed with an alkali and the formed gypsum dumped. (In some cases the double-alkali system is used: Firstly the gas is contacted with sodium carbonate to form sodium sulphate which is soluble and prevents scaling. The second step is to recover sodium carbonate by reacting the formed sodium sulphate with calcium carbonate to form sodium carbonate and gypsum which is dumped and the formed sodium carbonate is recycled to the scrubber.) Some smelters are considering giving away the gypsum to be used as an additive to Portland cement. In Botswana the only base metal smelter simply emits sulphur dioxide through a tall stack, though the sulphur dioxide concentration is ideally suited for acid manufacture. The cost of getting the acid to a market does not make it an economic proposition and current legislation allows them to dispose of the sulphur by dispersion via a tall stack. In Zambia and the DRC the ore bodies are generally sulphur deficient and apart from acid made from sulphur dioxide rich smelter gases they import large volumes of sulphur to make sulphuric acid for exploiting oxidized ores.

3 SULPHUR SUPPLY AND DEMAND

3.1 FIRST WORLD

With the introduction of strict environmental legislation as well as measures to ensure compliance the overall supply of sulphur and sulphuric acid generally exceeds demand in the developed world. In fact concern has been expressed that unless more uses for sulphur can be found in the near future, there may be a glut of sulphur in the West¹.

3.2 AFRICA

As far as the supply and demand situation for sulphur in Africa is concerned, it is a major importer of sulphur. South Africa alone imports some 1.5 million tons of sulphur per year from the Arabian Gulf and Canada. This is despite the fact that from the combustion of coal alone an estimated 1.3 million tons of sulphur is emitted into the atmosphere². To this needs to be added the base metal smelter emissions as well as the sulphur which reports to surface and underground waters from coal and base metal mining effluents. In addition an estimated 300,000 tons of sulphur ends up as gypsum on stockpiles and dumped in the sea from phosphoric acid plants. Currently a large proportion of the sulphur that does get captured from gases as well as liquid effluents ends up as gypsum (CaSO₄.2H₂O) on stockpiles. Unfortunately some of this gypsum is unsuitable for addition to Portland cement. These stockpiles create other environmental concerns such as air borne dust as well as effluent problems as gypsum is slightly soluble (2000 mg/l) in water.

Clearly there exists a need to develop methods to change poor quality gypsum into sulphur or other useful products.

4 USEFUL PRODUCTS FROM SULPHUROUS WASTES

4.1 ELEMENTAL SULPHUR FROM ACID MINE DRAINAGE (AMD) AND OTHER SULPHATE - RICH EFFLUENTS

Acid Mine Drainage (AMD) is formed when mine residues on surface or underground get exposed to water and oxygen. These residues are rich in pyrite (FeS₂) and pyrrhotite (FeS) which in contact with air and water get oxidized to sulphuric acid and iron sulphates.



Some of these effluents can have a pH as low as 2 and total sulphate as high as 20,000 mg/l. In most cases lime (CaO) is used to neutralize the effluent and precipitate any metals

Following calcium carbonate and lime neutralization, most of the remaining sulphate is removed by reacting it with barium carbonate.



The formed barium sulphate has a very low solubility (therefore used as radio opaque medium in diagnostic medicine). The resultant effluent can have a total sulphate value below 200 mg/l, which makes it suitable for drinking water. The formed barium sulphate is thickened and filtered. It is dried and mixed with coal. The mixture is subjected to a reducing roast in a kiln at 1000 °C to form barium sulphide.



The barium sulphide is dissolved in water and scrubbed with carbon dioxide from the kiln gases to form barium carbonate and hydrogen sulphide gas.

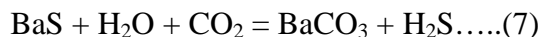

The barium carbonate is recycled back to the water treatment step and the hydrogen sulphide is converted into elemental sulphur through the PIPco⁵ process which is a modified Claus process. The PIPco process is unique in that 1/3 of the hydrogen sulphide is burned in excess air to sulphur dioxide. The sulphur dioxide is absorbed in a buffered potassium citrate solution and reacted at 123 °C with the rest of the hydrogen sulphide to form elemental sulphur.

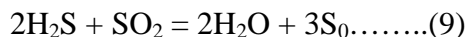

The elemental sulphur is of excellent quality as it is formed from a gas and contains virtually no impurities. It is a readily marketable product. It is estimated that effluent from one coal mine can produce as much as 60 tons/day of sulphur. The estimated capital cost is of the order of R 2 to 3 million /megaliter/day. The estimated total cost, operating as well as capital redemption, is of the order of R3 per kilo liter. This compares favorably with other methods.

4.2 ELEMENTAL SULPHUR FROM SMELTER, POWER STATION AND OTHER SO₂- BEARING GASES

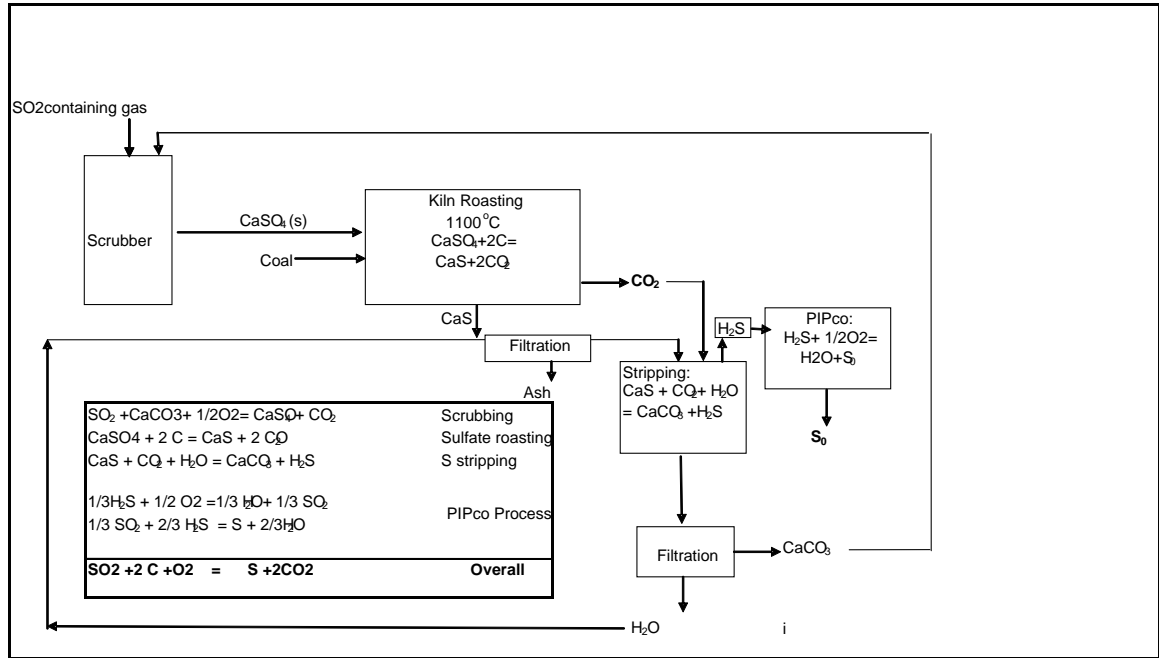
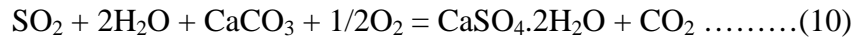
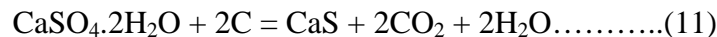

Fig 2 Elemental S₀ From Waste Gases

As a spin-off of Environmentek’s barium technology for water treatment, the CSIR and Pyroserv have developed a process very similar to the barium process for water treatment described above for treating gaseous effluents from smelters and power plants. See Fig 2 above. In this process limestone is used to scrub SO₂ containing off gases to form gypsum (CaSO₄.2H₂O).



The gypsum is thickened, filtered, dried and blended with fine coal. The only difference to the barium process shown above is that the temperature in the kiln is slightly higher. The mixture is subjected to a reducing roast at 1100 °C to form calcium sulphide.



The calcine is cooled, still under reducing conditions, and mixed with water. The calcium sulphide is soluble in water, especially when pH is dropped by bubbling through carbon

dioxide in a contact column. In the process the dissolved sulphide is converted into hydrogen sulphide and calcium carbonate as in reaction (7) above.



In order to separate the precipitated calcium carbonate from the ash, an excess of carbon dioxide is bubbled through the suspension to dissolve the calcium carbonate as calcium bicarbonate. The ash residues are then filtered off and calcium carbonate precipitated by bubbling air through to remove the excess carbon dioxide.

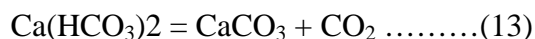

The calcium carbonate is so-called ‘chemically-precipitated-calcium-carbonate’ and fetches a high price as it is used in manufacturing high quality paper and pharmaceuticals. Alternatively the calcium carbonate can be recycled back to the scrubber. Whether calcium carbonate is sold or recycled depends entirely upon market conditions. The hydrogen sulphide is converted to elemental sulphur and water via the PIPco process as in reactions (8) and (9) above. Again the quality of the sulphur is very good as it is precipitated from a gas and therefore very pure. It likewise fetches a high price in the market.

The potential of recovering elemental sulphur from base metal smelter gases currently emitted to atmosphere in South Africa is only about 70 000 tons of sulphur per annum as most smelters have either acid plants or other means of capturing sulphur, such as lime scrubbing or double alkali scrubbing. On the other hand there is a huge potential for recovering sulphur from the coal fired power stations in South Africa which emit around 1.3 million tpa of sulphur.

In base metal smelters this process is especially appropriate in locations where there is no need for acid or on weak sulphur dioxide streams such as furnace gases, tap hole gases and acid plant tail gases. If there is an acid plant nearby the PIPco step can be replaced by a simple burner and waste heat boiler to burn the hydrogen sulphide to sulphur dioxide for adding to the acid plant gases. (The resulting gas will contain about 25-30 % SO₂). In other cases part of the hydrogen sulphide can be used to precipitate metals from solution.

5 OTHER POTENTIAL APPLICATIONS FOR THIS PROCESS

5.1 Phosphoric Acid Manufacture

In this process sulphur is purchased to make sulphuric acid which is reacted with the apatite (Ca₃(PO₄)₂) or rock phosphate to form phosphoric acid and gypsum. The gypsum is normally dumped or disposed of in the sea. Using the CSIR process the formed gypsum can be converted back into sulphur and calcium carbonate. This could save South Africa importing about 300 000 tpa of sulphur.

5.2 Coal fired boilers and power stations.

As mentioned earlier, some 1.3 million tons per annum of sulphur is emitted into the atmosphere from the combustion of coal in the RSA. Modern coal fired power stations have built in technology to take care of sulphur dioxide, but the older generation power plants have to be retrofitted with limestone scrubbers to capture the sulphur as gypsum. Normally this gypsum is stockpiled together with the ash. With the CSIR's technology this gypsum can be converted to sulphur and calcium carbonate, the latter can be recycled to the scrubber. Since the RSA is a net importer of sulphur, there is a ready market for the sulphur thus captured.

6. Status of This Technology

Neutralizing acidic effluents and scrubbing sulphurous gases with carbonates are proven technologies which need no further testwork. Carbothermic reduction of gypsum and barium sulphate has been proven in laboratory furnaces and partly in pilot kilns⁶. Some further scaled up kiln tests are planned for the near future to optimize conditions for commercially produced gypsums. Stripping of H₂S from CaS and BaS slurries have been proven at lab as well as pilot scale^{4,6}. The final step, viz the PIPco process to convert H₂S into elemental sulphur has been proven extensively in the USA. A pilot unit has been obtained and is being assembled in South Africa for verification tests under different operating conditions concomitant with stripping of H₂S from Ba and CaS slurries with kiln gas. A complete demonstration pilot plant is currently being designed which will allow all the steps of the process, i.e. from roasting, hydrogen sulphide stripping and PIPco processing of hydrogen sulphide into elemental sulphur to be tested at one location and will raise confidence for upgrading to any larger scale.

¹ Ober, Joyce A. (2003) *Sulfur 2002*.

www.minerals.usgs.gov/minerals/pubs/commodity/sulfur/sulfumyb02.pdf

² Johson, Elias.(2003) *South Africa Country Analysis Brief.htm/eia.doe.gov*

³ Maree, J.P.et al (2004) *Design Criteria for Limestone Neutralization at a Nickel Mine*. Mine Water and the Environment (2004) 23: 152-156 © IMWA Springer-Verlag 2004

⁴ Hlabela, P. et al (2004) *Treatment of Mine Water for Sulphate and Metal Removal using Barium Sulphide*. Waste Management, Emissions & Recycling in the Metallurgical & Chemical Process Industries (18-19 March 2004) Mintek, Randburg: 75-88

⁵ Gryka, George *The PIPco Sulphur recovery Process*
http://www.rcostello.com/acid_gas.gif

⁶ Nengovhela, Ryneth *Recovery of Sulphur From Waste Gypsum*. 20th International Conference on Solid Waste Technology & Management – Philadelphia USA 3-6 April 2005