

## **TECHNOLOGIES FOR THE BASE METAL CASTING INDUSTRY IN SOUTHERN AFRICA: THE IMPACT OF RAPID PROTOTYPING**

**Mr. Didier Kasongo NYEMBWE**  
**The Southern African Institute of Mining and Metallurgy**

### **Abstract**

The paper circumscribes the base metal casting industry in Southern Africa. It essentially consists in the founding of copper and zinc alloys. The challenge related to the scarcity and the unaffordable quality patterns and dies faced by the industry is discussed. New manufacturing technologies for foundry tooling called Rapid Prototyping that can possibly be used to alleviate the above mentioned challenge are then presented and their benefits assessed.

### **Introduction**

Copper and zinc are the base metals of interest to the metal casting industry in Southern Africa. In South Africa these base metal alloys rank respectively fourth and fifth in tonnage of cast metals after cast iron, steel and aluminum. However these alloys merely represented 3 percent of total metal poured to the finished shape in Southern Africa during 2006 year (figure 1).

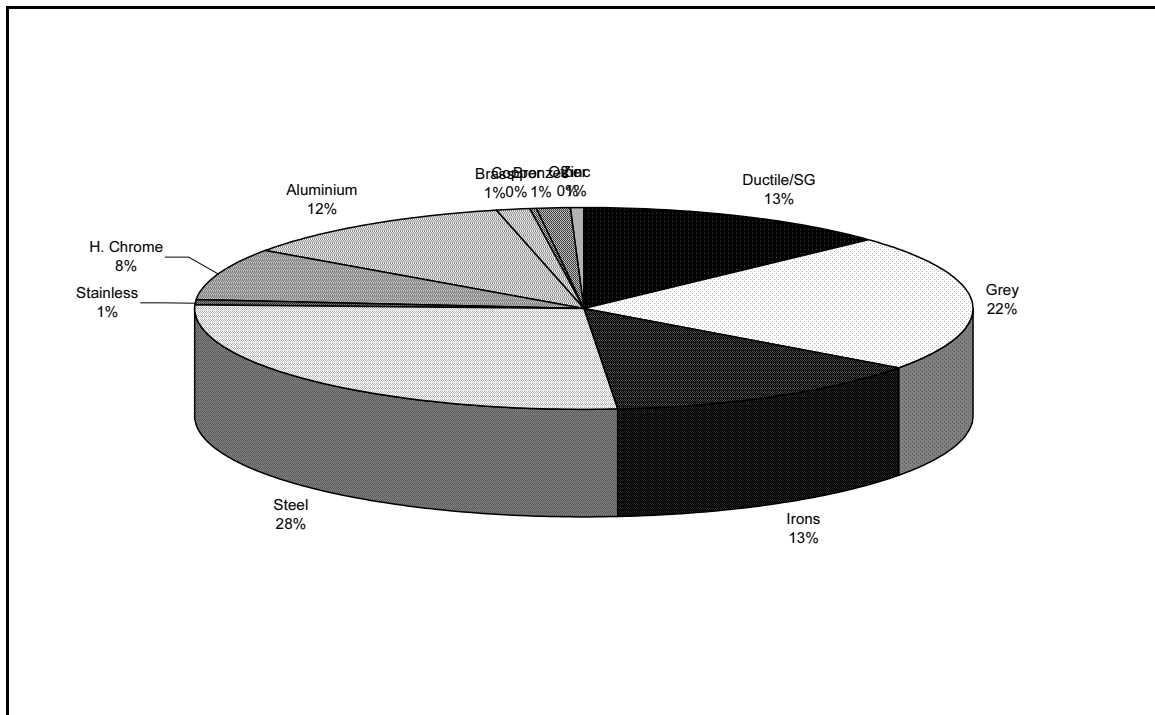

**Figure 1 - 2006 Metal cast tonnage distribution (Courtesy of the South African Institute of Foundrymen)**

Copper based alloys include brasses (copper - zinc) and bronzes (copper – tin, copper-tin-lead, copper-aluminum, copper- manganese- aluminum and copper -Nickel). These alloys are essentially used for their good corrosion, anti- friction and erosion resistance. The applications comprise plumbing fitting, bearings, impellers, cartridges, etc...Zinc alloys contain various additions of aluminum and magnesium. They are used for automotive parts, household utensils, building hardware, padlock and toys.

Sand casting and die casting are the predominant casting methods for the copper alloys while die casting is the principal casting method used for zinc alloys in Southern Africa. Sand Casting consists in pouring the molten metal in a refractory sand mould. The metal is allowed to solidify and the mould is destroyed to separate it from the final casting. The sand mould is obtained by ramming clay or resin bonded sand around a wooden or metallic pattern. Sand casting is the most popular casting method for copper alloys because it is cheap. However castings obtained from this casting method have relatively poor surface finish and dimensional accuracy.

On the other hand die casting is the use of metallic permanent moulds into which the molten alloy is either poured or injected under pressure, giving rise to the separate process of gravity and pressure die casting. Die casting use is confined, for practical purposes, to relatively few alloys such as zinc, magnesium and aluminum. This restriction is imposed by the limited capacity of dies materials to withstand intermittent contact with molten metals of high melting point: in addition the casting must solidify

and contract without cracking under condition of hindrance from die. Die casting is used for the mass production of small to medium size castings. This casting method confers a very good surface as well as dimensional accuracy.

Abundant foundry technology literature exists that provide details on the different types of copper and zinc alloys as well their melting and casting techniques. This paper intends to discuss a crucial challenge related to the scarcity and the unaffordable quality foundry tooling that the base metal casting industry in Southern Africa is facing. The paper then present new manufacturing technologies for foundry tooling called Rapid Prototyping that can possibly be used to alleviate the above mentioned challenge.

### **Foundry tooling challenge**

One of the characteristics of metal casting is the use of patterns or dies. The manufacturing of these foundry tooling is among the slowest and most expensive phases in the casting process because of the extremely high quality required. These tools have complex geometries, yet must be dimensionally accurate to within a hundredth of a millimeter. In addition, they must be hard, wear-resistant, and have very low surface roughness. To meet these requirements, patterns and moulds are traditionally made by CNC-machining, electro-discharge machining, or by hand. All these manufacturing techniques are expensive and time consuming.

In Southern Africa, the base metal casting industry is faced with the challenge of sourcing quality foundry tooling with high durability. Several factors are responsible for this state of things. Amongst others are:

- The disappearance of skilled pattern and die makers. This is due to the disappearance of old tool maker apprentice program. In South Africa, the government has identified this deficiency and is addressing it with initiatives such as the tooling initiative or the learnership program in foundry tooling manufacturing.
- Limited financial resources of base metal casting industry in Southern Africa. For instance in the case of South Africa, the fluctuating price of base metals and the interest rate increases over last years affect the profit margins and put financial constraints on the base metal foundries that are largely small and medium enterprise (SME). Foundry tooling is one of the most expensive capital equipment of foundries and more and more onerous to acquire. This problem is compounded by the jobbing nature of the base metal casting industry in Southern Africa requiring frequent purchase of dies or patterns.

As a result of the above, there is an inability to react quickly to customer demands and stringent casting quality requirements. This situation is negatively impacting on profitability and competitiveness of Southern African base metal industry. Recently this industry is loosing its market share to Asian base metal casting industry such as China and India.

Rapid prototyping technologies have slowly but surely made their entrance in Southern Africa especially in academic institutions. They provide an innovative new means of

manufacturing foundry tooling that can help alleviate the tooling problem of base metal casting industry in Southern Africa.

### **Rapid Prototyping Technologies**

The term rapid prototyping (RP) refers to a class of technologies that can automatically construct physical models from Computer Aided Design (CAD) data. These techniques are mainly based on the principle of layer manufacturing, in which solid models in plastic, paper or powder metals are generated.

Numerous rapid prototyping technologies exist and new ones are being invented everyday. Abundant and detailed literature is available that described these technologies. Figure 2 to 4 schematically described the functioning principle of Stereolithography (SLA), Laminated Object Manufacturing (LOM) and Selective Laser Sintering (SLS). These technologies are of interest to the base metal casting industry in Southern Africa.

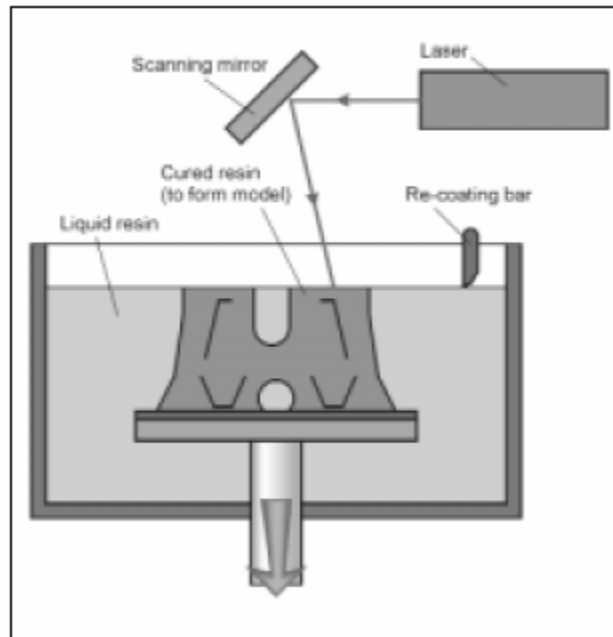

**Figure 2 - Schematic of SLA process** (Lerner, Y. (2001) Rapid Tooling in Metalcasting, Foundry Technology Management & technology)

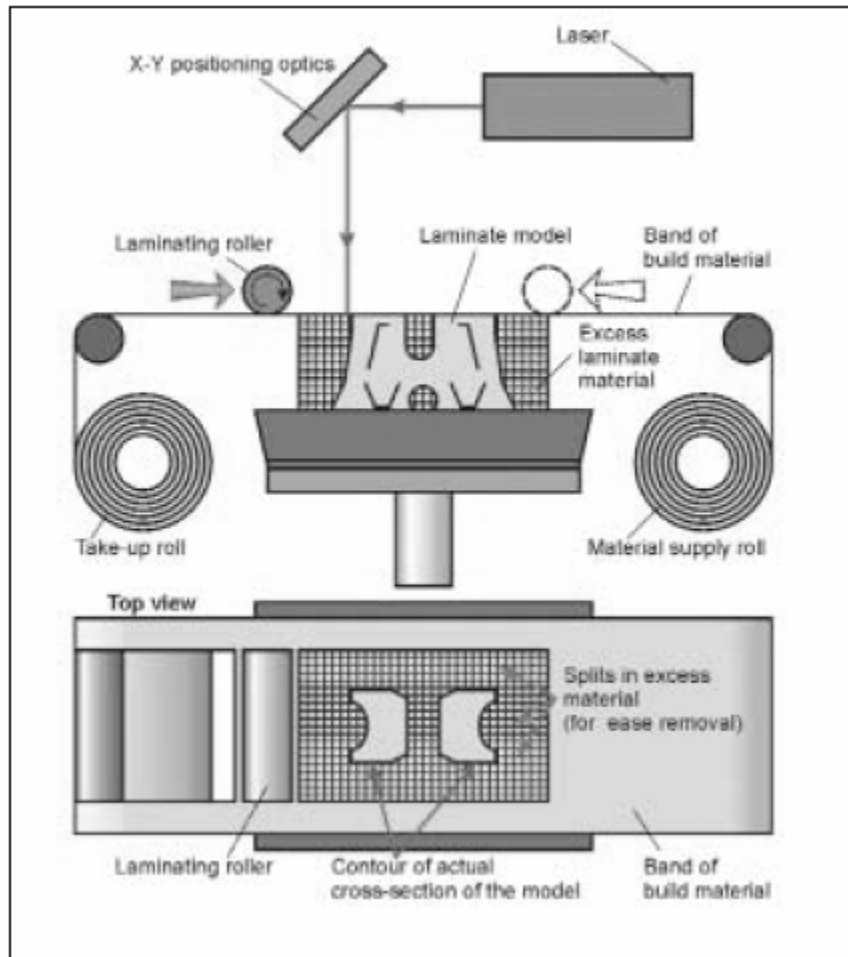

**Figure 3 - Schematic of LOM process** (Lerner, Y. (2001) Rapid Tooling in Metalcasting, Foundry Technology Management & technology.)

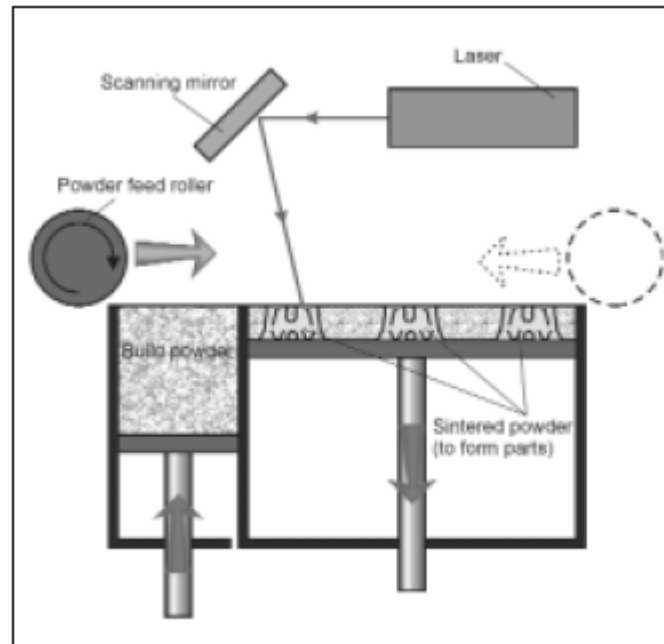

**Figure 4 - Schematic of SLS process** (Lerner, Y. (2001) Rapid Tooling in Metalcasting, Foundry Technology Management & technology)

Rapid tooling is the promising application of these technologies to the metal casting for the manufacturing of patterns and dies directly from CAD models. SLA and LOM models can be used as sand patterns, while SLS can be used for the manufacturing of dies suitable for gravity and high pressure die castings. These technologies allow producing foundry tooling that can be used for short run production in jobbing foundries. In addition these technologies also reduced the design time to produce casting prototypes from months to days.

RP technologies are still relatively expensive for most of the Southern African foundries. However with the recent developments their prices are continuously decreasing. They are available in South Africa:

- Stereolithography and Selective Laser Sintering at the Center for Rapid Prototyping at Free State Technikon in Bloemfontein
- Laminated Object Manufacturing at Pen Technikon and Stellenbosh University in Cape Town.

The literature mentioned some successful case studies on the use of RP technologies in Southern African base metal foundries. The result of the adoption of these technologies during the casting design stage helped to secure huge international contracts for the foundries.

## **Conclusion**

Copper and Zinc are the principal cast base metal in Southern Africa. The base metal casting industry is facing challenges regarding the sourcing of quality foundry tooling that result in the poor competitiveness of this industry. RP technologies such as SLA, LOM and SLS can allow the manufacturing of patterns and dies of suitable quality and affordable price for their use in Southern African base metal casting industry.

## **References**

- Ashley, S. (1995) Rapid prototyping is coming of age, *Mechanical Engineering*, vol.117, no. 7, pp 62-68
- Beeley, P. (2001) *Foundry Technology*, 2<sup>nd</sup> Edn. Butterworth-Heinemann, Oxford, pp 362 – 366
- Dimitrov, D. (2004) Advances in 3D printing – State of the art & future perspectives, in: *Proceedings of the 5<sup>th</sup> annual conference of Rapdasa*, Bloemfontein, South Africa
- Harlan, NR., Reyes, R., Bourel, DL., Beaman, JJ. (2001) Titanium castings using laser-scanned data and selective laser-sintered zirconia molds, *Journal of Materials Engineering and Performance*, Vol. 10(4), pp 410-413
- Kai, C., (2004) Investment casting using rapid prototyping patterns, URL [http://www.drc.ntu.edu.sg/groups/drc\\_www/projects\\_rp/ic/index.epl](http://www.drc.ntu.edu.sg/groups/drc_www/projects_rp/ic/index.epl)
- Lerner, Y. (2001) Rapid Tooling in Metalcasting, *Foundry Technology Management & technology*.

