

SKORPION ZINC SOLVENT EXTRACTION: THE UPSET CONDITIONS

J.M Musadaidzwa, E.I. Tshiningayamwe
Namzinc (Pty) Ltd,

ABSTRACT

Skorpion Zinc is located 25km North West of the small settlement of Rosh Pinah in southern Namibia. Commissioned in early 2003, Skorpion Zinc became the first mine-to-metal operation to commercially apply a purely hydrometallurgical process route to exploit a zinc oxide ore body. The novel technology, known as The Modified Zincex™ Process patented by Tecnicas Reunidas, comprises sulphuric acid atmospheric leaching, zinc solvent extraction (SX) and electrowinning (EW) to produce London Metal Exchange (LME) Special High Grade (SHG) zinc. Forming the core of the process, the SX step has thrived in its role as a barrier to impurities and also in the upgrading of the Pregnant Liquor Solution (PLS), converting it into a Loaded Electrolyte (LE) sufficiently rich and pure for EW. Against this successful run, a number of challenges have however been encountered in SX due the emergence of upset conditions largely emanating from upstream processes. This paper outlines some of the major deviations that have beset the SX process in its first five years of continuous operation. Impurity excursions, temperature depressions, changes in phase continuity, excess aqueous entrainment, the effect of colloidal silica and the accumulation of rare earth elements on the organic phase will be discussed in detail.

Keywords: Skorpion zinc, Solvent Extraction, The Modified Zincex™ Process (MZP) DE₂HPA, Aqueous entrainment (AE), Loaded Electrolyte (LE), Standard Liquid Validation (SLV) Test, Organic continuity, Aqueous continuity (AC), Electrowinning, Colloidal silica, Phase Disengagement Time (PDT), Rare Earth Elements (REE)

Introduction

Located in the Karas region of Namibia, Skorpion Zinc, an Anglo American operation comprises of an open cast Skorpion Mine and an adjacent Namzinc Refinery. The first operation in the world to incorporate SX technology to recover a primary zinc product from an oxide ore, the process represents a radical departure from conventional zinc refineries.[1] Commissioned in 2003, the operation realized its nameplate production of 150 000 tpa in 2007.

The complex oxidized silicate ore body, previously thought to be untreatable has zinc mineralisation mainly in the form of sauconite, hercynite and smithsonite at a plant head grade of 11.6% Zn. The gangue minerals are mainly quartz, K-feldspar and muscovite mica. Atmospheric acid leaching is utilized to yield a PLS that is forwarded to SX for further processing.

The SX circuit is based on a modification of The Zincex™ Process originally designed by Tecnicas Reunidas for secondary zinc sources. [2] The selection of SX as a purification step in the Skorpion process was necessitated by a number of factors. The choice of a cationic extractant ensures rejection of halides released from the ore. The chosen extractant, di-2-ethyl hexyl phosphoric acid, (D₂EHPA) an organo-phosphoric acid, possesses high zinc selectivity over the base metals present in the PLS namely, Ni, Cu, Co and Cd. The SX step concentrates and purifies the PLS prior to EW where trace, that is, as low as parts per billion impurity levels can be detrimental to the electrowinning process. In serving this function, the SX has however been afflicted by a number of operational challenges that have compromised the overall plant efficiencies. The co-extraction of impurities, temperature depressions, changes in phase continuity, excess aqueous entrainment the effect of colloidal silica and the accumulation of REE on the organic phase will be covered in detail.

The SX circuit

The SX circuit is comprised of three stages, extraction (three settlers), washing (three settlers) and stripping (two settlers), numbered MS001 to MS009. The settlers are of the conventional rectangular high density polyethylene (HDPE) lined concrete type arranged in a deliberate head to toe configuration to minimize the footprint of the circuit. The pump-mixer units installed on each of the settlers serves the dual purpose of pumping and mixing the aqueous and organic phases. Adequate settling and separation of the two phases is ensured by a large disengagement settling volume aided by settler internals i.e. distributor, picket fences and baffles. An aqueous recycle on each settler allows the variation of the individual organic to aqueous (OA) ratios to desired levels.

The PLS is introduced into the extraction circuit where zinc is selectively recovered using D₂EHPA extractant diluted with Escaid 100 in a 40 to 60% v/v mixture respectively. The extraction process proceeds through the cationic exchange reaction 1 below,

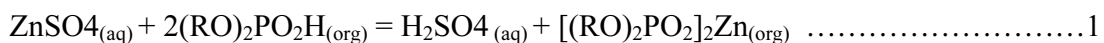

while the organic phase is stripped of zinc using spent electrolyte as in equation 2:

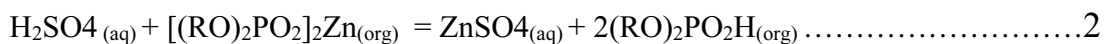

* (RO)₂PO₂H represents D₂EHPA.

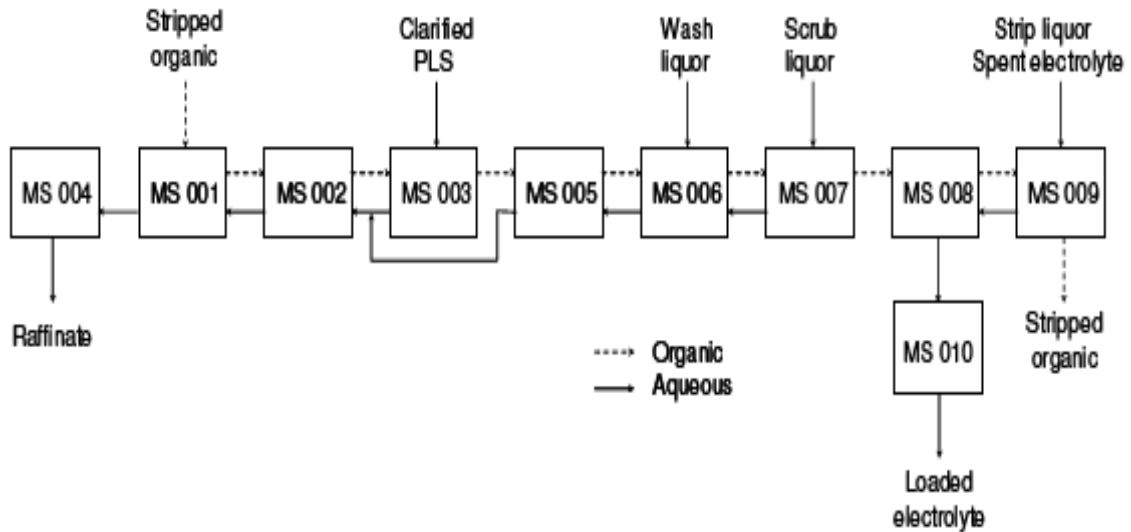
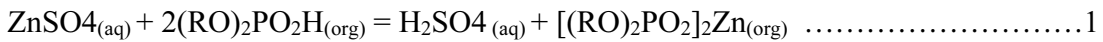
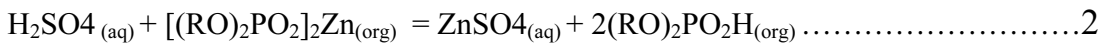

Figure 1: Schematic representation of the Skorpion SX circuit. [4]

The PLS is introduced into the extraction circuit where zinc is selectively recovered using D₂EHPA extractant diluted with Escaid 100 in a 40 to 60% v/v mixture respectively. The extraction process proceeds through the cationic exchange reaction 1 below,



while the organic phase is stripped of zinc using spent electrolyte as in equation 2:



* (RO)₂PO₂H represents D₂EHPA.

Escaid 100, kerosene with 20% aromatic content has been gradually replaced by a chemically similar Shellsol 2325 as of July 2008. After three counter current steps, and an initial Zn PLS tenor of 38g/l, the resulting raffinate stream contains 13 g/l Zn while the organic stream is loaded to 14g/l. The extraction process results in a zinc delta of 25g/l and generates a sulphuric acid tenor of 35 g/l which is returned to the leaching step in the raffinate.

The loaded organic phase is subjected to a three stage counter current washing process for impurity removal. The first two stages are predominantly physical, removing entrained aqueous phase and thus reducing the carryover of halides to the strip circuit while the third chemically scrubs off co-extracted impurities. [4] A mixture of spent electrolyte and demineralised water is used for aqueous entrainment (AE) removal while spent electrolyte is used in chemical washing. The relatively high Zn and acid values of

the wash solution and low impurity levels imposes the driving force for impurity stripping from the organic phase.

The washed organic phase is contacted with spent electrolyte (SE) in a two stage counter current stripping circuit. The high acid content of the SE (180g/l H₂SO₄) reverses the extraction equilibrium and the zinc is stripped back into the aqueous phase which is then forwarded to EW for plating.

Fe (III) present in the PLS in trace amounts is particularly detrimental to EW and is more strongly complexed to DEHPA than Zn. In this state, the Fe³⁺ is reduced to Fe²⁺ at the cathode while the reverse reaction takes place at the anode. This redox effect consumes power and significantly reduces the current efficiency. However, the acidity of the SE is not sufficient to strip it off the organic.[3] Its removal is achieved by a separate organic regeneration circuit in which a bleed stream of the organic raffinate is contacted with 6M HCl solution.

The upset conditions

The effects of impurity excursions, temperature, phase continuity, colloidal silica and REE accumulation on the overall SX step are discussed in detail separately below.

Impurity excursions

The production of SHG zinc cathodes requires an extremely pure electrolyte and this is a circumstance of zinc's position in the electromotive series. [4] As such, impurity carry over into the loaded electrolyte (LE) is detrimental to the operation of the electrowinning stage (EW). Elevated levels of these impurities can result in their co-deposition and thus contamination of final product, changes in orientation and morphology of cathode deposit, the formation of 'sticky zinc', reduced current efficiency and hydrogen (H₂) evolution which increases the risk of H₂ fires at electrowinning. [5, 6] Hydrogen fires in EW due to increased concentrations of impurities in the loaded electrolyte forced plant shut downs in 2005 and 2006.

Base metals (Ni, Cu, Co, Cd) constitute the bulk of the impurities in the PLS and are normally rejected by the solvent extraction (SX) step to within acceptable levels. The order of extraction of metal ions by acidic extractants generally parallels the order of metal hydrolysis constants, and under similar conditions, is also indicative of the relative stabilities of the metal-extractant species. The selectivity of D₂EHPA with different pH conditions is depicted in Figure 2.

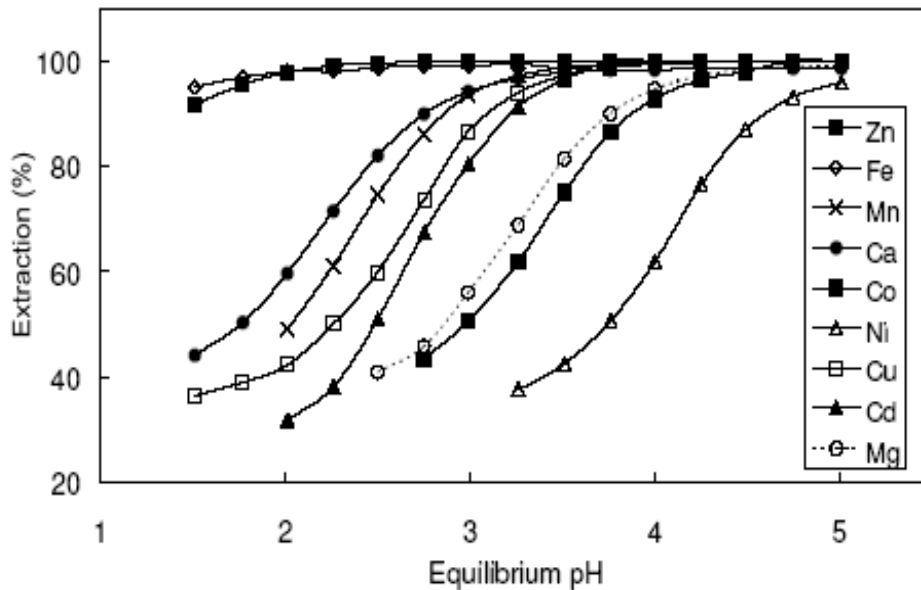

Figure 2: Effect of pH on the extraction selectivity of D₂EHPA. Conditions: 40 vol.% D₂EHPA in Escald 100, 40 °C 30g/l Zn in feed. [1]

Results from sampling have indicated that this general order of selectivity is defied, particularly in the case of nickel. Its co-extraction with Zn ahead of the rest of the impurities has been observed in the plant and corroborated by SLV tests. This is more prominent in times of a high impurity background in the electrolyte. The mechanism by which nickel is co-extracted has not been identified at Skorpion although the degradation of the diluent has been sited as a probable cause. The oxidation of aromatic components of the diluent by cobalt has been reported to yield carboxylic acids which are known to be nickel extractants thus potentially leading to a significant uptake of nickel.[6]

In addition to co-extraction by D₂EHPA, impurities can be carried over across SX by aqueous entrainment (AE) in the organic phase, via occlusion or surface adsorption on crud or by another mechanism involving the degradation of the extractant or diluent.[7] Crud in hydrometallurgy can be defined as the thermodynamically stable, non-coalescing, interfacial deposits occurring within the settler of an SX operation.[8] The plots in Figure 3 show the relationship between the third washing stage aqueous entrainment and impurity carry over in electrolyte during an excursion episode in August 2008.

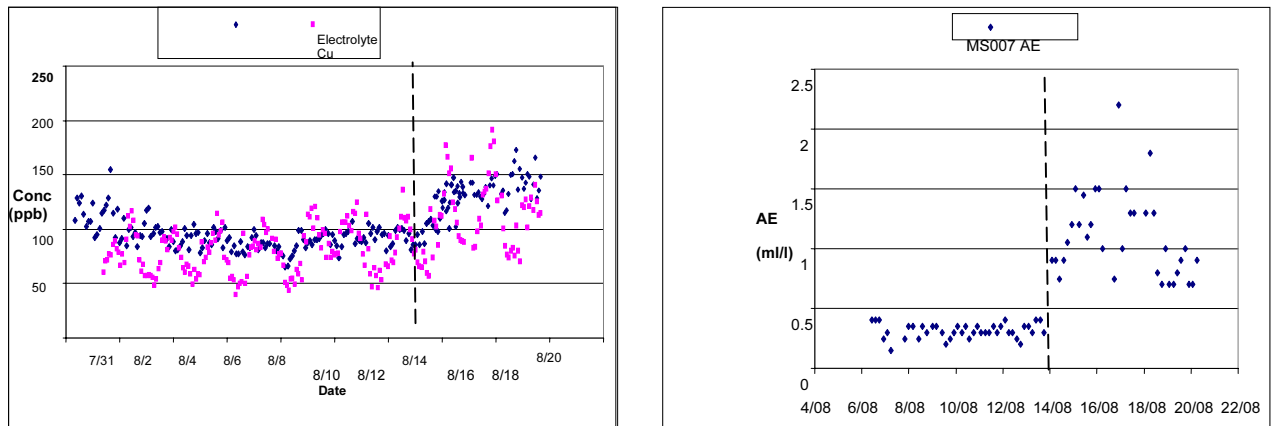

Figure3: (a) Impurity carryover in electrolyte and **(b)** MS007 aqueous entrainment (AE) for days in August 2008.

The elevated aqueous entrainment levels were attributed to a general decline in settler temperatures brought about by PLS temperatures below the target of 40⁰C. This was in turn due to operational difficulties in the leach section. The aqueous entrainment and consequently the impurities dropped to usual levels upon normalisation of the PLS temperatures.

Temperature

Optimum extraction performance has been shown to be obtained with the extraction circuit controlled at 40-45⁰C. Because the reaction is endothermic, higher temperatures improves zinc extraction but also increases co-extraction of impurities. [9] Temperature variations impact on the viscosity of the organic phase and thus the phase disengagement rates. The extraction efficiency and plant capacity are heavily inhibited at operating temperatures below 40⁰C in the extraction circuit. Under conditions of low operating temperatures, the OE and AE in the aqueous and organic phases respectively have been observed to increase significantly. The control of temperature within the desired ranges is also critical to the efficiencies in the adjoining leaching and EW circuits. The plots in Figure 4 show the effects of temperature on phase disengagement for both phases. Generally, the phase disengagement times vary inversely with temperature for both continuities.

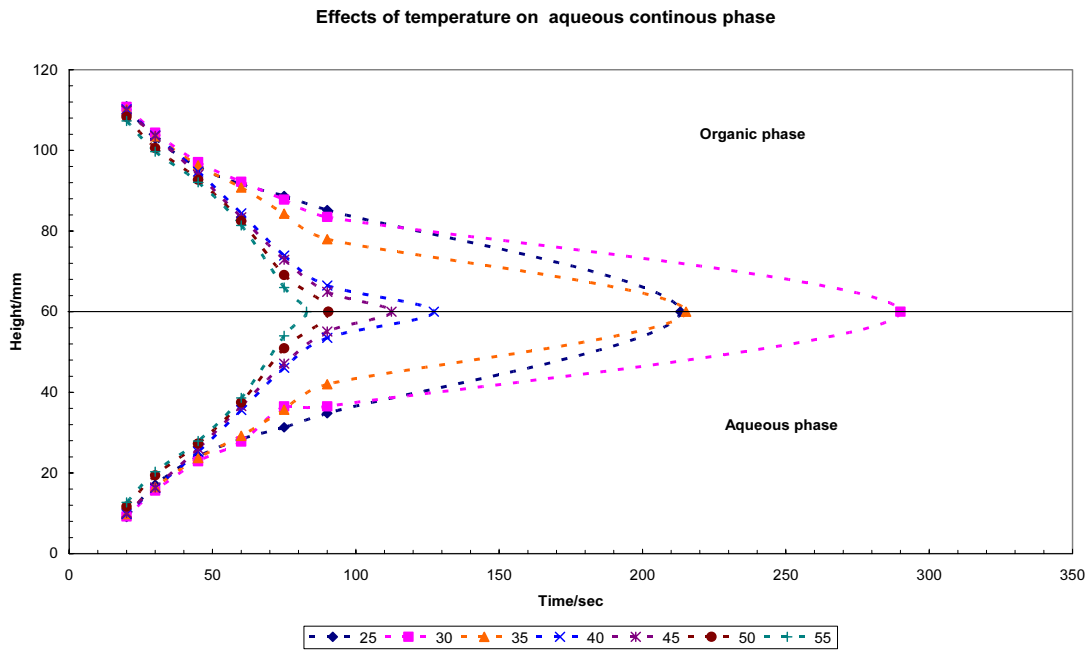

Figure 4a: Effect of temperature on aqueous continuous phase disengagement time, (July 2007).

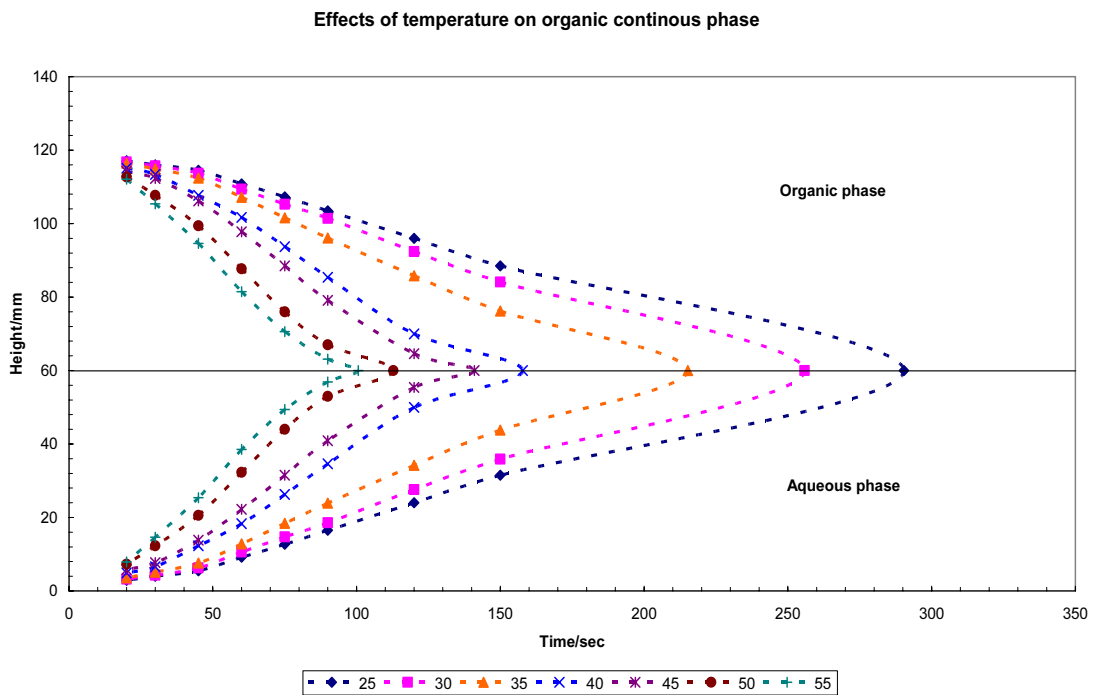

Figure 4b: Effect of temperature on organic continuous phase disengagement time, (July 2007).

Phase continuity

Aqueous continuity (AC) represents the dispersion of organic droplets in the aqueous phase and organic continuous (OC) the reverse. The phase continuity at a given settler is primarily determined by its position in the train, function and the phase of the exit product stream. A mixer-settler operating in OC phase produces a clean aqueous discharge relative to the organic discharge and vice versa. Generally, AC mixtures display faster liquid-liquid disengagements compared to OC mixtures. In addition to the said effect, phase continuity also impacts on the dispersion band depth and crud stability characteristics.

Originally designed to operate in AC, the first washing stage (MS005) continuity was flipped in 2006 after persistent floating gummy crud excursions. Upon switching to OC, the floating crud got modified and reported to the interface and settler bottom. In 2008 an OC to AC flip was attempted at MS002 to address an operational instability and the resultant crud modification is depicted in Figure 5. A marked jump was reported in the quantity of both the interface and bottom crud in MS002 and this pointed to a crud modification occurrence in which the crud morphology and density were altered. Interface crud is prone to further modifications and transformation into floating crud. By virtue of its capacity to carry impurities upstream, floating crud is more detrimental to EW than bottom crud. As such the phase continuity at MS002 was reverted back to OC.

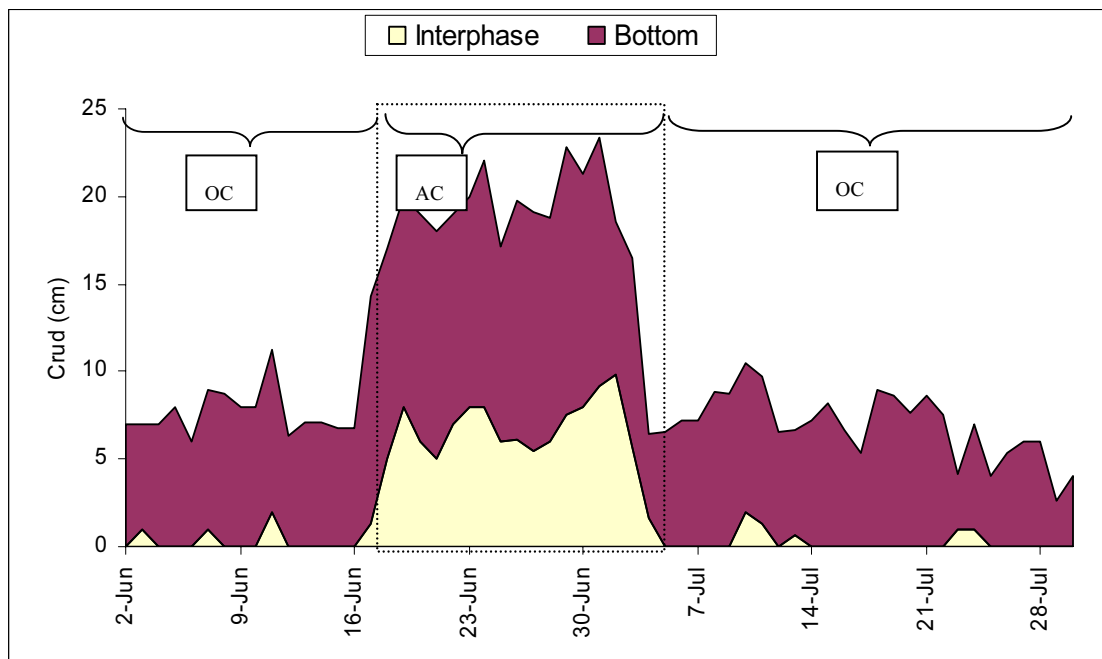

Figure 5: MS002 Crud modification with change in continuity.

In addition to the quantity and composition of the total suspended solids in the PLS, the results observed demonstrated that settler continuity plays a key role in determining the nature and distribution of crud within the settler body.

Colloidal Silica

The Skorpion ore contains an average of 25.9% Si, considerably higher than conventional zinc concentrates. [10] After acid leaching, the resultant siliceous species are often implicated as the causes of crud in SX. Silica may exist in any of three possible forms in solution with each form having a markedly different effect on the SX system. The first form of silica in solution is suspended silica. These solids particles have generally not been allowed time to settle out of solution. Once entrained in an emulsion, this form of silica is capable of contributing to the volume of crud. The second form of silica is dissolved silica. Dissolved siliceous species, the simplest form of which can be represented by the molecular formula $\text{Si}(\text{OH})_4$ (monosilicic acid) remain in solution under conditions where its solubility is not exceeded.[8] Low pH excursions in the leach section reduces the selectivity of the leaching process resulting in an increase in the dissolved silica. [1] In the case where solution conditions such as pH, temperature, or dissolved salts concentration change, it is possible for dissolved siliceous species to polymerise to the third form of silica, colloidal silica. These siliceous polymers, sized from 1nm to 100nm have a massive surface area, but are still small enough to be affected by gravity. Colloidal-sized polysilicic molecules can cause serious problems in an SX system by stabilising emulsions.[1] The resultant colloidal silica which forms irreversibly can combine to form either open structures, within which water is bound (silica gel) or crystalline coagulates, depending on the process conditions. [6]

In October of 2008 a yellowish gel started to form and accumulate in MS003 (first extraction settler). The non coalescing gel accumulated on the interface and was stable for a couple of days until it was removed by a settler clean out. The gel, approximately 5-10cm in depth at the settler discharge end, disrupted normal settler operation particularly the phase disengagement kinetics. A combination of the pH and temperature conditions at the leaching and neutralisation stages and a change of these conditions into SX is the most probable reason for the transformation of dissolved silica into colloidal silica. Figure 6 depicts the change in PLS colloidal silica levels over the period of concern.

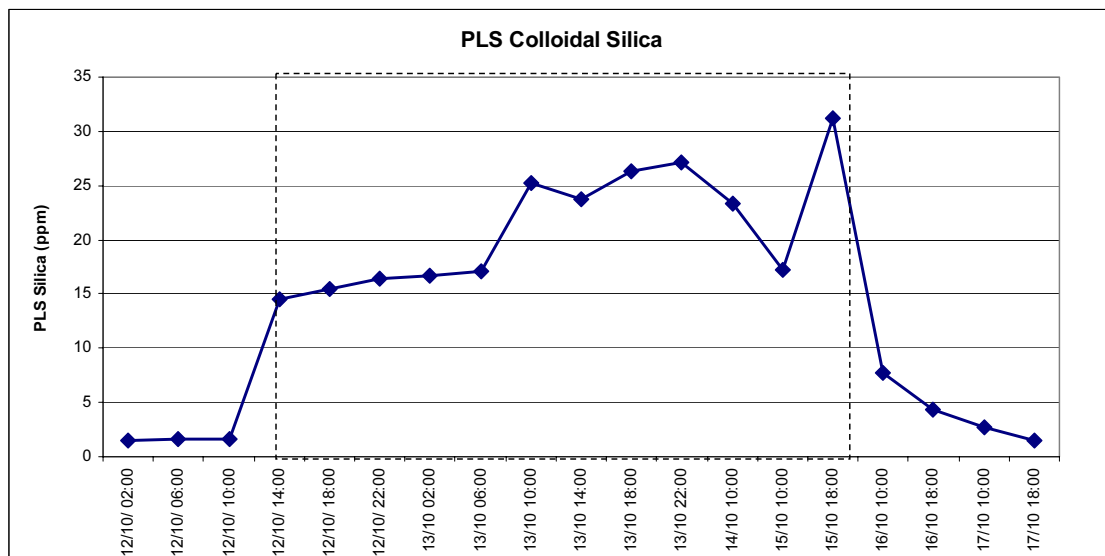

Figure 6: PLS colloidal silica composition over the period of gel formation.

Accumulation of REE on the organic phase

Analysis of the organic phase has shown the presence of REE especially the heavy end of the spectrum namely Er, Tm, Yb, Lu, Sc and Y. DE₂PHA is a very strong extractant for REE and is used in the commercial extraction of REE such as lanthanum [8]. Although present in the ore in trace amounts and below the detection limit in PLS, the closed-loop nature of the SX-EW circuit has seen the gradual accumulation of these elements. [7] Occurring in the trivalent state or higher, the REE bond strongly with DE₂PHA and cannot be removed by the acidity in the stripping section. The 6M HCl used in the organic regeneration circuit at an organic to aqueous (O/A) ratio of 6.7 removes less than 10% of the total metal ions which leads to accumulation. Under the Skorpion conditions, the middle REE range has been observed to report to the electrolyte. [7]

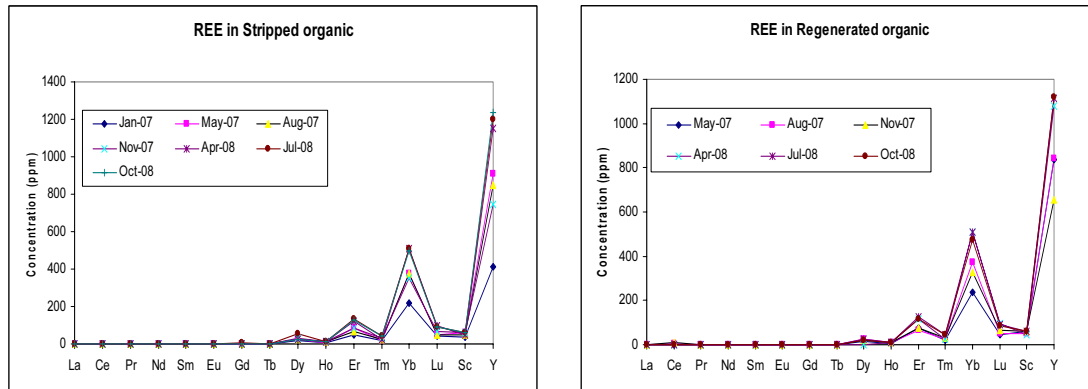

Figure 7: (a) REE content in stripped organic (b) REE content in regenerated organic phase.

Quantitative stripping tests carried out at the laboratory have however demonstrated REE removal efficiencies of up to 50% at an O/A ratio of 1. The plots in Figure 7 demonstrate how the REE have accumulated to about 2g/l on the organic phase. This represents 5 % of the chemical saturation loading level of 40g/l. Under the obtaining phase dilution, the organic phase has a maximum loading of 30g/l. [11] As a result, an excess of bonding sites are still available for Zn with no obvious detrimental effects being observed on the organic health so far. Work is however in progress to establish a process route for stripping off the REE and maintaining them within acceptable levels.

Conclusions

The Skorpion Zinc SX circuit has successfully managed to upgrade, purify, and transfer the desired amounts of dissolved zinc to EW. An improvement in the understanding of the process since 2003 can be attributed to the achievement of nameplate production of 150 000tpa in 2007. The focus on an integrated approach in managing the leach-SX and SX-EW loops has enabled the refinery to consistently produce SHG zinc, indicating the flexibility and robustness of the Modified Zincex Process in dealing with a host of upset process conditions. Despite the highlighted upsets and numerous other challenges faced since commissioning, the circuit has convincingly demonstrated the efficiency of this purely hydrometallurgical process route for treating primary zinc.

References

1. J. Gnoinski., "Skorpion Zinc: Optimisation and Innovation," Africa's Base Metals Resurgence, Southern African Institute for Mining and metallurgy, Johannesburg, 2007; pp.329-342.
2. Gnoinski J., Bachmann T., Holtzhausen S., "Skorpion Zinc: Defining the cutting edge of zinc refining", Proceedings of the International Symposium on Lead and Zinc Processing, Koto, Japan, 2005, 1315-1325.

J M Musadaidzwa and E I Tshiningayamwe

3. E.A. Roux., M.J. Sechemene., and S. Holzhausen., “Iron Removal in the Skorpion Process”, Iron Control technologies, J.E. Dutrizac and P.A. Riveros, Eds., Canadian institute of Mining, Metallurgy and Petroleum, Montreal, 2006; pp. 491-500.
4. Gnoinski J., K.C Sole., “The influence and benefits of an upstream solvent extraction circuit on the electro winning of zinc in sulphate media: the Skorpion Zinc Process
5. K.C Sole., R.J. Stewart., R.F. Maluleke., A. Rampersad., E. Mavhungu.2007. “Removal of entrained organic phase from zinc electrolyte: Pilot plant comparison of CoMatrix and carbon filtration”, Hydrometallurgy, 89:11-20.
6. Gnoinski J., “Investigation into the nature and cause of impurity spikes through the SX circuit at Skorpion Zinc“, Report No. SKP-2211 Rev 0.
7. Gnoinski J., K.C Sole., D.R. Swart., R.F. Maluleke., G. Diaz., and F. Sanchez. 2008. Highlights and hurdles in zinc production by SX: The first four years at Skorpion Zinc. International SX Conference ISEC2008, B. Moyer (ed), Canadian Institute of Mining, Metallurgy and Petroleum, Montreal, in press.
8. C.A Morais., V.S.T Ciminelli. 2004. “Process development for the recovery of high-grade lanthanum by solvent extraction”, Hydrometallurgy, 73:237-244.
9. Sole, K. C., “Preliminary assessment of the options for reconfiguration of the Skorpion Zinc solvent extraction circuit in the event of failure of one mixer settler stage“, Anglo American Research Laboratories, Project No. A200500144, Report No. 1.
10. “Skorpion Zinc Project, Metallurgical Piloting and Test work”, Final Report, 2000.
11. “Modified Zincex Process, Skorpion Project, Training course handbook, Solvent Extraction Plant”, Tecnicas Reunidas, Report No. ITR/P-4554/047/2001

The Author



James Munetsi Musadaidzwa, *Technical Metallurgist*, Skorpion Zinc

February 2009 to Current – **Technical Metallurgist , Electrowinning & Cast House**, Skorpion Zinc Mine & Refinery, Namibia

May 2007 to February 2009 – **Technical Metallurgist, Solvent Extraction & Projects**, Skorpion Zinc Mine & Refinery, Namibia

November 2004 to September 2005 – **Metallurgist, Smelter**, Bindura Nickel Corporation, Zimbabwe

January 2004 to November 2004– **Metallurgist, Refinery**, Bindura Nickel Corporation, Zimbabwe

September 2003 to December 2003 – **Metallurgist, Concentrator**, Bindura Nickel Corporation, Zimbabwe

