

## FLWSHEET CONSIDERATIONS FOR COPPER-COBALT PROJECTS

A.Nisbett<sup>1</sup>, K Baxter<sup>2</sup>, K Marte<sup>3</sup>, M Urbani<sup>4</sup>

<sup>1</sup>Cognis Corporation, USA

<sup>2</sup>Bateman Engineering Pty Ltd, Australia

<sup>3</sup>Bateman Engineering Canada Corporation, Canada

<sup>4</sup>Western Minerals Technology, Australia

### **Abstract**

The Copperbelt areas of Zambia and the Democratic Republic of Congo (DRC) have recently been seeing the development of a significant number of new projects. Due to the current economic climate some of these projects have been delayed but the region remains an important resource for copper and cobalt for future years.

Many of these projects will utilize an agitation leach followed by solvent extraction and electrowinning to recover both copper and cobalt. The flowsheet route for copper is fairly well established while the processing options for cobalt vary considerably depending on the final product (metal or salt) the operator wishes to make. The mineralogy of ores in the area is typically associated with high gangue acid consumption during the leaching process. This has resulted in acid availability to the area being constrained and acid prices have risen accordingly.

Agitation leach circuits typically have a delicate water balance which needs to be maintained and a certain volume of aqueous needs to be continuously removed from the circuit in order to maintain this balance. This bleed typically contains fairly high levels of acid and requires neutralization prior to tailings disposal or secondary metal recovery. It is therefore desirable to minimize the acid concentration in this bleed stream in order to decrease total acid requirements and neutralization costs.

An in-depth case study by Cognis and Bateman Engineering evaluated three different flowsheets with the aim of determining relative operating costs between the three alternatives, together with differences in plant capital cost requirements.

### **1. INTRODUCTION**

Copper and cobalt production from oxide ore types in the African Copperbelt by agitation leaching followed by solvent extraction (SX) and electrowinning (EW) has been practiced for many years. The Tailings Leach Plant at Nchanga in Zambia was commissioned in 1974 and is still in operation today <sup>(1)</sup>. In recent years more of these types of plants have been constructed and successfully operated by mining companies

such as First Quantum Mining and Metorex <sup>(2)</sup>. The recent global financial crisis and dramatic down turn in the price of copper has resulted in several other similar projects being suspended pending improved financial conditions. The region is still considered a valuable resource of base metals for future years.

Cognis and Bateman conducted a review of three different flowsheet configurations that could be applied to a plant treating typical Copperbelt ores. The aim of the review was to identify configurations that minimise overall acid consumption to minimise project exposure to this issue. The review comprised an evaluation of leaching, solid-liquid separation and solvent extraction circuit configurations to maximise net revenue from the overall flowsheet.

## **2. BASIS OF DESIGN**

The basis of the plant design is the treatment of an oxide/secondary sulphide deposit treating a 4 percent copper head grade and a 0.05 percent cobalt head grade at a treatment rate of 2.5 million tons per annum. This will provide a feed tonnage of 100 000 tons and 1325 tons per annum of copper and cobalt respectively.

The design basis of the various unit operations within the flowsheet and reagent additions were set to levels typical of the oxide ores in the Copperbelt and consistent with the process plant from which the model was designed.

Gangue acid consumption was set at 80 kg/ ton for all options considered.

## **3. FLOWSHEET CONFIGURATIONS**

Three different flowsheets were considered for this review and are described below. Basic outputs (stream flows and copper and acid concentrations) from the Metsim model are included in the relevant schematics.

### **3.1 Flowsheet 1 – Conventional Circuit**

Flowsheet 1, the Conventional Circuit, is a simplified (and amended to include cobalt recovery) version of the metallurgical flowsheet that has been in use for many years at the Tailings Leach Plant at Nchanga, Zambia <sup>(1)</sup>. It provides the base case for this study and comprises a single train circuit utilising an atmospheric leach followed by a CCD train with CCD1 overflow providing the pregnant leach solution (PLS) for copper SX. A bleed stream of copper SX raffinate is neutralised to remove acid, and copper and cobalt are recovered by sequential precipitation. This flowsheet is the simplest configuration for this type of circuit.

The copper SX circuit comprises three extraction stages and two stripping stages (3E x 2S).

The raffinate bleed is treated through a two stage iron removal circuit, with the first stage removing the majority of the acid, iron and manganese. The precipitate from the second stage removes residual copper, iron and acid and is recycled to the atmospheric leach. Cobalt is then recovered by precipitation.

The basic flowsheet is illustrated in Figure 1 below

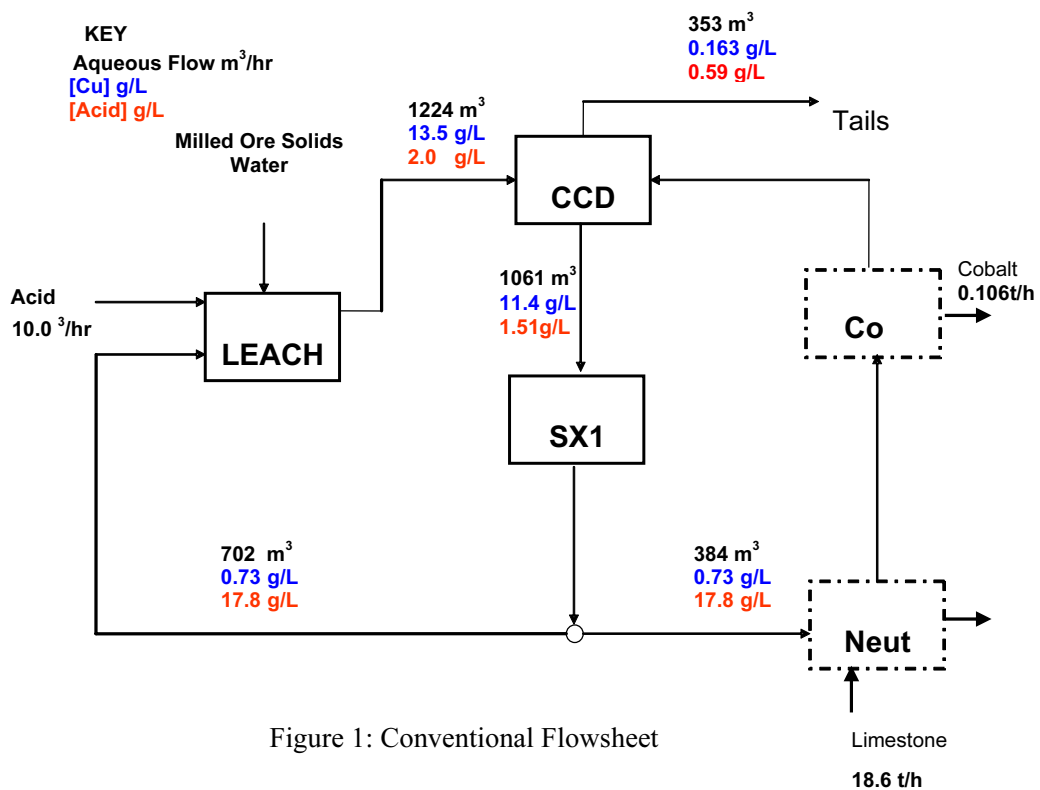

Figure 1: Conventional Flowsheet

### 3.2 Flowsheet 2 – Split Circuit™

Flowsheet 2 is a Split Circuit modification of the base case to evaluate the impact of generating separate high and low tenor raffinates to maximize recycle of acid to the atmospheric leach, thus minimizing fresh acid makeup. This is achieved using one of the CCD thickeners as a single “split thickener” on the leach discharge to produce an undiluted high grade (HG) copper tenor stream that is treated in one SX train. The resultant raffinate is recycled to leach. The split thickener underflow is then treated in a

CCD circuit with wash to produce a low grade (LG) copper tenor for treatment in a second SX circuit.

SX circuit 1 (HG) comprises three extraction stages and two stripping stages (3E x 2S) and SX circuit 2 (LG) comprises two extraction stages and one stripping stage (2E x 1S).

A bleed of SX2 raffinate is similarly treated through an iron removal circuit and the cobalt is again recovered by precipitation. The acid and sulphate loading on the iron

removal circuit is substantially lower than the base case which minimizes acid loss from the overall circuit and, in parallel, neutralization costs and cobalt entrainment losses.

The basic flowsheet is illustrated in Figure 2.

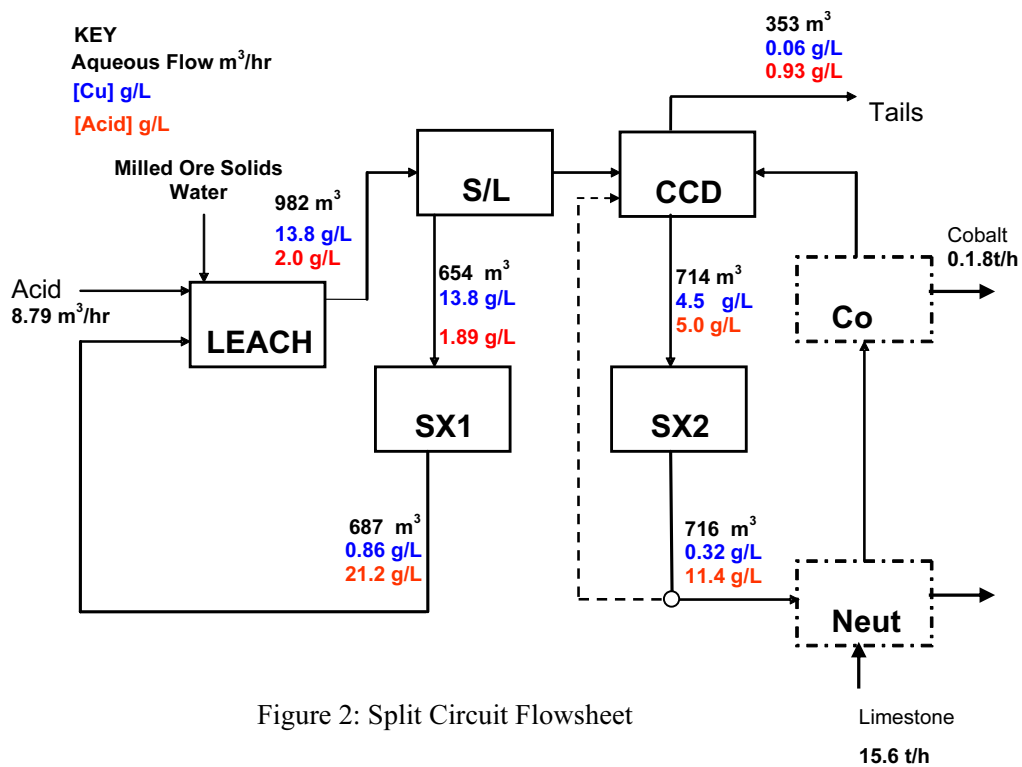

Figure 2: Split Circuit Flowsheet

### 3.3 Flowsheet 3 – Sequential Circuit.

Flowsheet 3, the Sequential Circuit, is based on a split leaching technique concept to maximize retention of acid in the leach circuit, thus minimizing acid loss to the cobalt circuit and the associated treatment costs thereof.

The circuit configuration comprises two leach trains in series with an intermediate solid/liquid separation stage from which the first SX circuit derives its feed. SX1 raffinate is recycled to the head of the leach. A second solid/liquid separation stage follows the second leach circuit which again is closed with a second SX circuit with the resultant raffinate recycled back to the head of the second leach circuit.

Underflow discharge from the second solid/liquid separation is washed in a CCD circuit which in turn produces a PLS for treatment in a final SX circuit. A bleed of this raffinate reports to the iron removal and cobalt recovery circuits described earlier.

Acid and sulphate loading on the iron removal circuit is now substantially lower than the base case to an extent that exceeds the Split Circuit flowsheet.

SX1 comprises a 3E x 2S configuration, while SX2 comprises a 2E x 1S. SX3 is a single extraction stage that is incorporated into SX1 in a parallel configuration, so essentially there are still only two SX trains in Flowsheet 3.

The basic flowsheet is defined in Figure 3

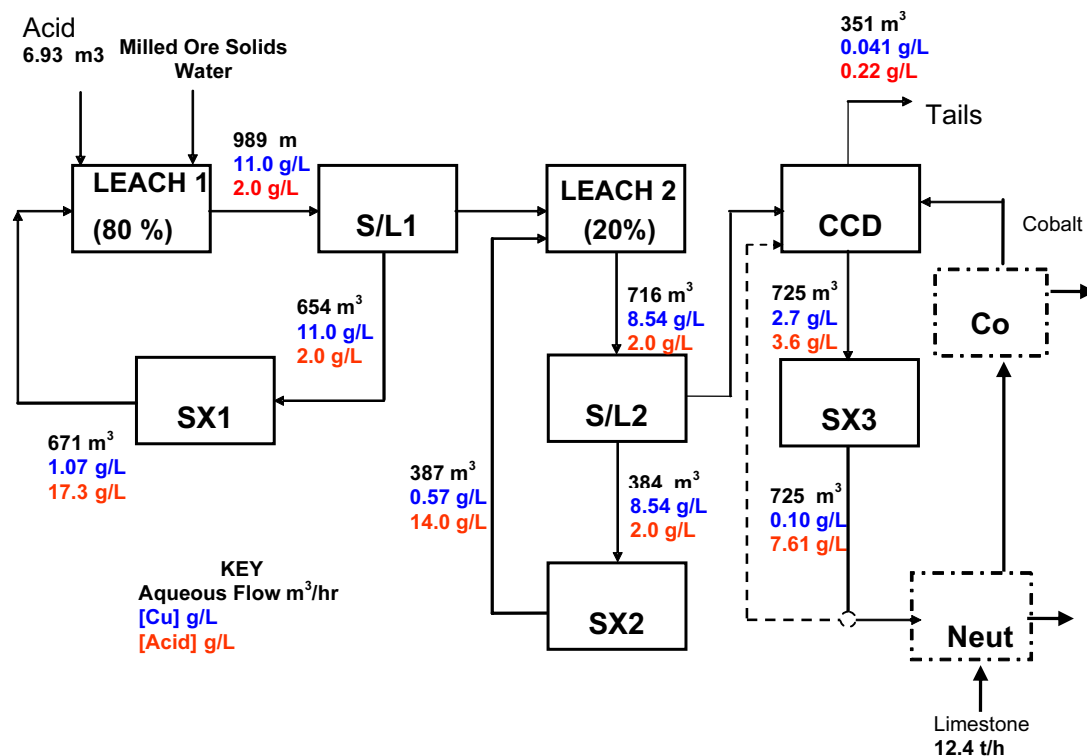

Figure 3: Sequential Flowsheet

#### **4. METSIM AND ISOCALC™ MODELLING**

The Metsim models utilized in this analysis were derived from a fully detailed engineering model developed as part of the engineering design for an oxide leach circuit. The base model was modified as required to develop the three flowsheets discussed, keeping the basic design parameters of the unit operations unchanged across the three options.

The model is inclusive of all the design and engineering components required for detailed design, hence the derived models provide a very comprehensive basis on which to compare the performance of the three flowsheets.

A number of iterations of each circuit were performed using Cognis Isocalc software to predict the copper extractions attainable for each solvent extraction circuit in order to refine the copper extraction performance.

#### **5. KEY OPERATING DATA AND DISCUSSION**

A summary of key operating data derived from the Metsim models for the three different flowsheets is presented in Table 1 below.

		Flowsheet		
<b>Leaching</b>	Units	Conven'al (1)	Split(2)	Sequential(3)
Exiting pulp SG – Train 1	%	23.7	23.8	24.2
Exiting pulp SG – Train 2	%			23.8
<b>CCD</b>				
CCD Wash Recovery	% Cu	96.9	99.4	99.5
	% Co	96.7	87.0	88.8
CCD Wash Ratio	Prim	1.30	1.58	1.58
	Second		2.68	2.68
<b>Bleed Treatment</b>				
Flowrate to Fe removal	m <sup>3</sup> /hr	385	467	478

<b>Products</b>				
Cu cathode	t/a	89,403	89,844	89,977
Co	t/a	840	853	883
<b>Reagents</b>				
Acid consumption	t/h	19.4	17.0	13.7
Limestone consumption	t/h	18.6	15.3	11.9

Table 1: Key Operating Data

The data shows some interesting features derived from the flowsheet design in each case

Cobalt wash recoveries are higher for flowsheet 1 compared to the other flowsheets. The decrease in wash recovery produced by flowsheets 2 and 3 can be attributed to the use of cobalt containing SX raffinate being returned to the CCD as secondary wash and added mid way in the train. This extra wash utilization is necessary to complete the water balance. There is also effectively one less CCD stage in flowsheets 2 and 3 compared to flowsheet 1

However, CCD recovery for cobalt should not be viewed in isolation. Cobalt recovery across the bleed circuit also contributes to ultimate cobalt recovery and reduced cobalt losses as a result of lower wash and co-precipitation losses in the bleed circuit have a significant influence. The amount of discard precipitate generated decreases from flowsheets 1 through 3 due to the lower acid tenors reporting to these units and therefore the associated cobalt soluble losses incrementally decrease.

## **6. RESULTS**

The results of the Metsim modeling are detailed in tables below. The data extracted from the Metsim models has been utilised to develop;

- Preliminary revenue projections
- Operating cost differentials against the flowsheet 1 base case
- Capital cost differentials against the flowsheet 1 base case
- Net revenue projections

All of the flowsheet options presented in this paper are technically feasible and some are in commercial production<sup>(3)</sup>. Comparison of the derived data for each flowsheet

highlights the strong linkage between the control of the overall circuit sulphate balance and the operating cost of each individual circuit. Improved project revenue streams can be achieved by careful manipulation of the flowsheet sulphate balance through an understanding and application of principles discussed in this paper to an individual project.

## 6.1 Revenue

Differential revenue projections have been developed utilizing flowsheet 1 as the base case. Due to the widely fluctuating metal prices that have occurred in the last 18 months it was decided to perform the revenue projections on both a “high” and “low” metal value basis;

- High: Cu – \$3.40 /lb, Co - \$45 /lb
- Low: Cu – \$1.25 /lb, Co - \$12.8 /lb

The results of these calculations are shown in Tables 2 and 3

Parameter	Units	Flowsheet		
		Conven'al (1)	Split(2)	Sequential(3)
Copper	t/a	89,403	89,844	89,977
Gross revenue	\$USM/a	670	673	674
Differential	\$USM/a	0.00	3.31	4.30
Cobalt	t/a	840	853	883
Gross revenue	\$USM/a	83.3	84.6	87.6
Differential	\$USM/a	0.00	1.31	4.27
Total	\$USM/a	0.00	4.61	8.57

Table 2: Revenue Projection based on high metal pricing

Parameter	Units	Flowsheet		
		Conven'al (1)	Split(2)	Sequential(3)
Copper	t/a	89,403	89,844	89,977
Gross revenue	\$USM/a	246	248	248



Differential	\$USM/a	0.00	1.22	1.58
Cobalt	t/a	840	853	883
Gross revenue	\$USM/a	23.7	24.1	24.9
Differential	\$USM/a	0.00	0.37	1.21
Total	\$USM/a	0.00	1.59	2.80

Table 3: Revenue Projection based on low metal pricing

## 6.2. Capital Cost Differentials

Plant equipment requirements vary for the three flowsheets. The conventional flowsheet is the most basic of designs with additional equipment, and therefore capital expenditure, being required to change to flowsheets 2 and 3 respectively. Table 4 below highlights major equipment changes between the three flowsheets.

Area	Flowsheet		
	Conven'al (1)	Split(2)	Sequential(3)
Leaching	5 Leach Tanks	5 Leach Tanks	5 Leach Tanks
S/L Separation	8 Thickeners 1 Pin Bed Clarifier (PBC)	+ 1 PBC	+ 1 Thickener + 2 PBC
Solvent Extraction	1 Train (3E x 2S)	+ 1 Train (2E x 1S)	+ 1 Train (2E x 1S) + 1 Train (1 EP)
	PLS/Raff Ponds	+1 set of ponds	+ 2 set of ponds
Cobalt Recovery	Base Case	Scaled up	Scaled up

Table 4: Major Equipment Changes

## 6.3 Net Revenue Estimates

Differential capital costs for the equipment changes described above have been estimated from Bateman's equipment capital cost database and represent costs on an installed basis.

Operating costs have been estimated based on consumable quantities derived from the Metsim models. The impact of labour and power costs were reviewed and found to be negligible. Maintenance costs have been factored from the overall capital cost in each case.

A major contributor to the operating costs differentials between the three flowsheets is the price of acid. Once again, the cost and availability of this consumable has fluctuated widely over the past 18 months. For this reason, the financial analysis was performed under two different scenarios;

High: - Cu \$3.40 /lb, Co \$45/lb and Acid \$300/ton

Low: - Cu \$1.25 /lb, Co \$12.8/lb and Acid \$150/ton

Net Revenue estimates taking into account Gross Revenue, Operating Cost and Capital Cost differential estimates for both scenarios described above are shown in Tables 5 and 6 respectively. A simple straight line payback is also calculated.

Differential Costs	Units	Flowsheet		
		Conven'al (1)	Split(2)	Sequential(3)
Gross Revenue	\$USM/a	Base Case	4.61	8.57
Operating Cost	\$USM/a		- 6.2	- 14.4
Net revenue	\$USM/a		10.8	23.0
Capital Cost	\$USM		5.18	11.3
Straight Line payback	months		5.7	5.9

Table 5: Net Revenue Estimate based on High prices

Differential Costs	Units	Flowsheet		
		Conven'al (1)	Split(2)	Sequential(3)
Gross Revenue	\$USM/a		1.59	2.80
Operating Cost	\$USM/a		- 3.37	-7.65

Net revenue	\$USM/a	Base Case	4.96	10.4
Capital Cost	\$USM		5.18	11.3
Straight Line payback	months		12.5	13.0

Table 6: Net Revenue Estimate based on Low prices

## 7. DISCUSSION

Flowsheets 1 and 2 have been installed commercially and the key issues in terms of circuit configuration and operation are well understood. Flowsheet 3 is not installed but is presented here as a basis for the future development of more cost effective flowsheets.

Flowsheet 1 presents the base case which is a simple leach train, CCD train with attendant copper SXEW circuits with a bleed of copper raffinate treated through iron removal and a cobalt precipitation circuit to recover cobalt.

Flowsheet 2 presents the split circuit variant of the base case, which requires separate processing of two leach liquors and in this study, and two solvent extraction circuits to implement. This type of flowsheet has proven to be readily operable on a commercial scale.

Flowsheet 3 is a new flowsheet proposed by Cognis as a means of improving plant operation, and the focus of this paper has been to evaluate the performance of this circuit against flowsheets 1 and 2 and to determine whether this is a viable option to be considered. Additional mechanical equipment is required to allow the atmospheric leach train to be separated into two trains by an intermediate thickener. The circuit then requires three solvent extraction circuits to function although in reality the third solvent extraction train is nominally one settler incorporated into the first solvent extraction train hence the overall increase in circuit complexity is minimal. This flowsheet splits the leach train at a point where the majority of the copper has been leached and utilises a thickener to recover the majority of the leached copper which is treated through solvent extraction to produce a raffinate which is recycled back to the head of the leach circuit. The function of this circuit is to limit sulphate as either acid or copper passing further

down the leach train as this sulphate ultimately contributes to the sulphate load in the circuit bleed stream, incurring acid losses and neutralisation costs.

The second half of the leach circuit is likewise closed with a thickener and the second solvent extraction circuit and the sulphate load of the circuit is reduced by the extent of sulphate associated with copper in the first half of the leach train. Copper raffinate from the second solvent extraction circuit is likewise recycled to the head of the second half of the atmospheric leach train.

Overall the requirement of the CCD circuit to recover the remaining copper is considerably reduced in comparison with the base case flowsheet.

A split addition CCD train has been used for flowsheets 2 and 3 although consideration can be given to reverting to a conventional CCD train to improve cobalt recovery. Modelling has indicated a marginal improvement in net return utilising a conventional CCD circuit in comparison to this split addition CCD circuit variant.

This study assumed that 80 percent of the recoverable copper is leached in the first leaching step. This number could be substantially lower or even marginally higher depending on the characteristics of the ore being treated and the equipment available. Laboratory scale leaching studies to establish a leach rate relationship can be used in conjunction with the Metsim model to more accurately define this number, and the sulphate deportment implications thereof, on a project specific basis.

Overall, flowsheet 3 reduces the sulphate mass flow to the bleed circuit by reducing the copper concentration present in a generated PLS that would ultimately report to the bleed stream. Stoichiometrically, 1.54 g/L of acid is generated for every 1 g/ L of Cu extracted during the solvent extraction process and therefore a lower tenor PLS would result in a lower acid tenor raffinate produced. This in turn contributes to a reduction in the

neutralisation costs of the bleed stream and concurrent cobalt wash and co-precipitation losses.

## **8. CONCLUSIONS**

- Flowsheet configuration variations can be used to minimise operating costs and in particular to reduce the level of consumables required, which is an important issue for remote sites with a long logistics train.
- All of the flowsheets presented in this paper are technically feasible and some are in commercial production. However, while the current review is not exhaustive in terms of the analysis presented, it is intended to identify concepts which can improve project economics in the current climate. On a project specific basis further flowsheet optimisation is possible based on metal grade and pricing, and in capital and operating cost inputs.
- The aim of the paper is to present for consideration the net revenue impact of three flowsheet options of somewhat increasing complexity. Clearly flowsheet 3 presents the best net revenue projections, but from our current understanding a flowsheet of this configuration has never been in commercial production.

- Provision of two and three solvent extraction trains adds circuit complexity but has the advantage of providing a degree of redundancy in the event of an SX fire and the additional costs of the SX circuits can be accommodated in the overall project economics by savings in other areas.
- Overall, flowsheet 3 offers potential for operating cost savings that are worth consideration.

## **9. REFEEERENCES**

[1] J.A Holmes, A.D Deuchar, L.N Stewart and J.D Parker. “Design, Construction and Commissioning of the Nchanga Tailings Leach Plant”. In: *Extractive Metallurgy of Copper*. J Yannopoulos and J Agarwal (eds), Metallurgical Society of AIME 1976, Volume II, pages 907-925

[2] G Kordosky, A Feather and G Chisakuta. “The Copperbelt of Africa – New Plants and New Technology in Copper Hydrometallurgy”. In: *Proceedings Alta 2008 Copper Conference*, Perth, Australia 2008

[3] A. Nisbett, A. Feather and G. Miller. “Implementation of the Split Circuit™ Concept into Copper Agitation Leach Plants”. In: *Proceedings HydroCopper 2007*, Vina del Mar, Chile, 2007, pages 185-190

### **The Author**



**Andrew Nisbett**, *Global Project Manager*, Cognis Corporation

Graduated from the University of Johannesburg (formerly Technikon Witwatersrand) in 1986 with a National and Higher National Diploma in Extractive Metallurgy. I was employed by Mintek till 1995 and gained experience in the gold, uranium, platinum group metal and base metal industries in the fields of mineral processing and hydrometallurgy. In 1995 I joined Cognis (formerly Henkel) and was involved in the development and marketing of reagents used in flotation and solvent extraction. I

relocated to the USA in 2002 with Cognis and am currently the Global Project Manager for the Mining Chemicals Technology group of Cognis. Primary responsibilities are for the development of new chemistries and processes for copper hydrometallurgical circuits and working with current and prospective Cognis customers on new projects. Member of the SAIMM and SME